



TRANSPORTATION CABINET

Frankfort, Kentucky 40622
www.transportation.ky.gov/

Steven L. Beshear
Governor

Michael W. Hancock, P.E.
Secretary

October 17, 2011

CALL NO. 106
CONTRACT ID NO. 111048
ADDENDUM # 2

Subject: Fayette County, STPM 3003 (250)
Letting October 21, 2011

- (1) Revised - Plan Sheets - S1 & S16
- (2) Revised - Bid Items - Pages 110 of 110

Proposal revisions are available at <http://transportation.ky.gov/contract/>.
Plan revisions are available at <http://www.lynnimaging.com/kytransportation/>.

If you have any questions, please contact us at 502-564-3500.

Sincerely,

A handwritten signature in blue ink that reads "Ryan Griffith".

Ryan Griffith
Director
Division of Construction Procurement

RG:ks
Enclosures



An Equal Opportunity Employer M/F/D

TRANSPORTATION CABINET DEPARTMENT OF HIGHWAYS

FAYETTE COUNTY NEWTOWN PIKE EXTENSION NOISE BARRIER WALL AT NORFOLK SOUTHERN RAILROAD YARD

INDEX OF SHEETS	
SHEET NO.	DESCRIPTION
S1	TITLE & ESTIMATE OF QUANTITIES
S2	GENERAL NOTES
S3	TYPICAL SECTIONS
S4	GENERAL PLAN & ELEVATION
S5-S15	PLAN & ELEVATION
S16	DRILLED SHAFTS
S17	PILASTER DETAILS
S18	PANEL DETAILS
S19-S37	CROSS SECTIONS
S38-S49	SUBSURFACE DATA
SPECIAL NOTES	
(6J) NON-EPOXY ADHESIVES	
(11C) DRILLED SHAFTS	
NONDESTRUCTIVE TESTING OF DRILLED SHAFTS	
EROSION PREVENTION AND SEDIMENT CONTROL	
SPECIAL PROVISIONS	
SPECIAL PROVISIONS FOR PROTECTION OF RAILROAD INTERESTS	
STANDARD DRAWINGS	
RDH-020-03	SLOPED AND FLARED HEADWALLS FOR 12' - 27' CIRCULAR PIPE CULVERTS
SPECIFICATIONS	
2008 KYTC STANDARD SPECIFICATIONS FOR ROAD AND BRIDGE CONSTRUCTION	
2002 17th EDITION AASHTO STANDARD SPECIFICATIONS FOR HIGHWAY BRIDGES	
GUIDE SPECIFICATIONS FOR STRUCTURAL DESIGN OF SOUND BARRIERS 1989 WITH INTERIMS	

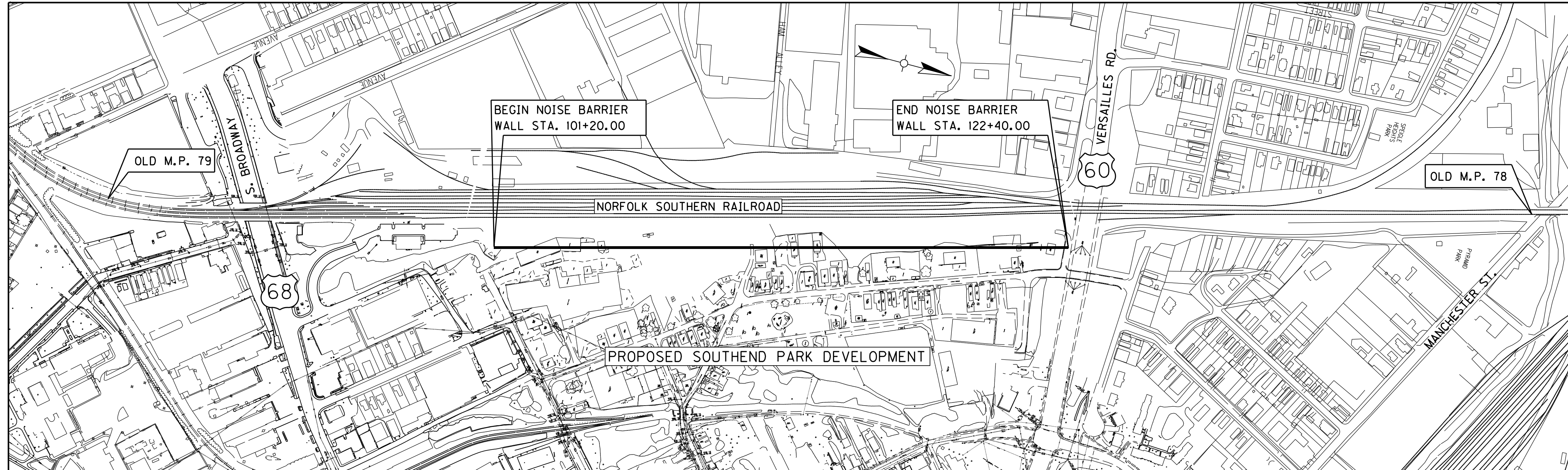

LAYOUT MAP
N. T. S

NOTE:
MILE POINTS TAKEN FROM TRACK MAP
V-1-KY, S-40a & S-40b, (1931, UPDATED
1994 AND 1997.)

ESTIMATE OF QUANTITIES

BID ITEM CODE	21590EN	23583EC	23584EC	21321NC	0461	2230	2483	2545	2568	2569	2726	2998	5950	8100	8150	20745ED	20746ED	23143ED	2555
BID ITEM	SOUND BARRIER WALL	DRILLED SHAFT 48" COMMON	DRILLED SHAFT 42" ROCK	CSL TESTING (4 TUBES) ①	CULVERT PIPE - 15"	EMBANKMENT IN PLACE	CHANNEL LINING CLASS II	CLEARING AND GRUBBING ②	MOBILIZATION	DEMOLITION	STAKING	MASONRY COATING	EROSION CONTROL BLANKET	CONCRETE CLASS A ③	STEEL REINFORCEMENT	ROCK SOUNDING	ROCK CORING	KPDES PERMIT TEMP. EROSION CONTROL	CONCRETE CLASS B
UNIT	SF	LF	LF	EACH	LF	CY	TON	LS	LS	LS	LS	SY	SY	CY	LB	LF	LF	LS	CY
NOISE BARRIER WALL	51484	688	589	14	112	15735	10.5	1	1	1	1	5720	12832	4.5	42	346	899	1	25

① QUANTITY BASED ON 14 OF 54 DRILLED SHAFT LOCATIONS

② APPROXIMATE AREA OF CLEARING AND GRUBBING IS 2.6 ACRES

③ CONCRETE FOR SLOPED AND FLARED HEADWALLS, SEE STD DWG RDH-020-03

▲ BID ITEM ADDED		10/13/11
REVISION		DATE
DATE: 09/2011	CHECKED BY	
DESIGNED BY: M. LAWLER	D. KAISER	
DETAILED BY: E. TRIMBLE	M. LAWLER	
Commonwealth of Kentucky DEPARTMENT OF HIGHWAYS		
COUNTY FAYETTE		
NOISE BARRIER WALL AT NORFOLK SOUTHERN RR YARD		
TITLE & ESTIMATE OF QUANTITIES		
ITEM NUMBER	PREPARED BY	SHEET NO.
7-593.11		S1
		DRAWING NO. 26505

SHEET LOCATION:

FILE NAME: \$\$\$design\$file\$specification\$\$\$

USERNAME: \$\$\$USER\$\$\$

DATE: \$\$\$DATE\$\$\$

E-SHEET NAME:

TRANSPORTATION CABINET DEPARTMENT OF HIGHWAYS

FAYETTE COUNTY NEWTOWN PIKE EXTENSION NOISE BARRIER WALL AT NORFOLK SOUTHERN RAILROAD YARD

INDEX OF SHEETS	
SHEET NO.	DESCRIPTION
S1	TITLE & ESTIMATE OF QUANTITIES
S2	GENERAL NOTES
S3	TYPICAL SECTIONS
S4	GENERAL PLAN & ELEVATION
S5-S15	PLAN & ELEVATION
S16	DRILLED SHAFTS
S17	PILASTER DETAILS
S18	PANEL DETAILS
S19-S37	CROSS SECTIONS
S38-S49	SUBSURFACE DATA
SPECIAL NOTES	
(6J) NON-EPOXY ADHESIVES	
(11C) DRILLED SHAFTS	
NONDESTRUCTIVE TESTING OF DRILLED SHAFTS	
EROSION PREVENTION AND SEDIMENT CONTROL	
SPECIAL PROVISIONS	
SPECIAL PROVISIONS FOR PROTECTION OF RAILROAD INTERESTS	
STANDARD DRAWINGS	
RDH-020-03	SLOPED AND FLARED HEADWALLS FOR 12" - 27" CIRCULAR PIPE CULVERTS
SPECIFICATIONS	
2008 KYTC STANDARD SPECIFICATIONS FOR ROAD AND BRIDGE CONSTRUCTION	
2002 17th EDITION AASHTO STANDARD SPECIFICATIONS FOR HIGHWAY BRIDGES	
GUIDE SPECIFICATIONS FOR STRUCTURAL DESIGN OF SOUND BARRIERS 1989 WITH INTERIMS	

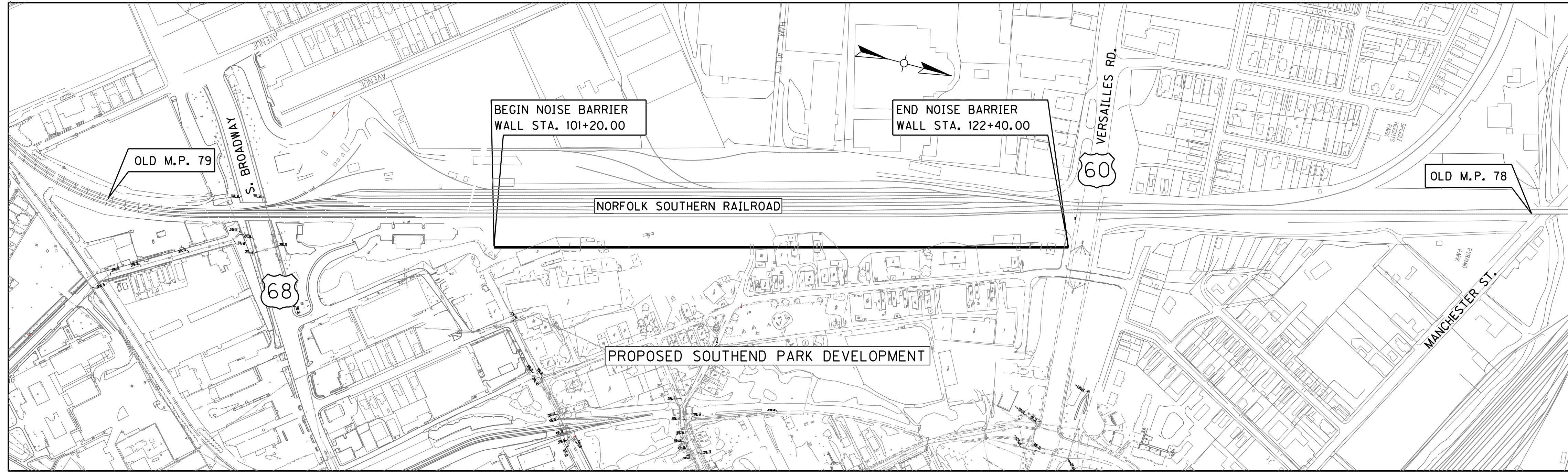

LAYOUT MAP
N. T. S

NOTE:
MILE POINTS TAKEN FROM TRACK MAP V-1-KY, S-40a & S-40b, (1931, UPDATED 1994 AND 1997.)

ESTIMATE OF QUANTITIES																			
BID ITEM CODE	21590EN	23583EC	23584EC	21321NC	0461	2230	2483	2545	2568	2569	2726	2998	5950	8100	8150	20745ED	20746ED	23143ED	2555
BID ITEM	SOUND BARRIER WALL	DRILLED SHAFT 48" COMMON	DRILLED SHAFT 42" ROCK	CSL TESTING (4 TUBES) ①	CULVERT PIPE - 15"	EMBANKMENT IN PLACE	CHANNEL LINING CLASS II	CLEARING AND GRUBBING ②	MOBILIZATION	DEMOLITION	STAKING	MASONRY COATING	EROSION CONTROL BLANKET	CONCRETE CLASS A ③	STEEL REINFORCEMENT	ROCK SOUNDING	ROCK CORING	KPDES PERMIT TEMP. EROSION CONTROL	CONCRETE CLASS B
UNIT	SF	LF	LF	EACH	LF	CY	TON	LS	LS	LS	LS	SY	SY	CY	LB	LF	LF	LS	CY
NOISE BARRIER WALL	51484	688	589	14	112	15735	10.5	1	1	1	1	5720	12832	4.5	42	346	899	1	25

- ① QUANTITY BASED ON 14 OF 54 DRILLED SHAFT LOCATIONS
- ② APPROXIMATE AREA OF CLEARING AND GRUBBING IS 2.6 ACRES
- ③ CONCRETE FOR SLOPED AND FLARED HEADWALLS, SEE STD DWG RDH-020-03

△ <i>BID ITEM ADDED</i>		10/13/11
REVISION		DATE
DATE: 09/2011	CHECKED BY	
DESIGNED BY: M. LAWLER	D. KAISER	
DETAILED BY: E. TRIMBLE	M. LAWLER	
Commonwealth of Kentucky DEPARTMENT OF HIGHWAYS COUNTY FAYETTE		
NOISE BARRIER WALL AT NORFOLK SOUTHERN RR YARD TITLE & ESTIMATE OF QUANTITIES		
ITEM NUMBER	PREPARED BY	SHEET NO.
7-593.11		S1
		DRAWING NO. 26505

SHEET LOCATION: FILE NAME: \$\$\$design\$file\$specification\$\$\$ USER NAME: \$\$\$USER\$\$\$ DATE: \$\$\$DATE\$\$\$ E-SHEET NAME:

SHEET LOCATION: FILE NAME: USER: DATE: E-SHEET NAME:

DRILLED SHAFT GENERAL NOTES

- DRILLED SHAFTS FOR THE NOISE WALLS SHALL BE CONSTRUCTED IN ACCORDANCE WITH THE 'SPECIAL NOTES FOR DRILLED SHAFTS', CURRENT EDITION. THE USE OF SUPERPLASTICIZERS IN THE CLASS 'A MODIFIED' CONCRETE IS NOT RECOMMENDED.
- CONCRETE FOR DRILLED SHAFTS SHALL BE CLASS 'A MODIFIED', WITH A 28 DAY STRENGTH OF 4000 psi.
- PAYMENT FOR DRILLED SHAFTS SHALL BE EITHER DRILLED SHAFT, COMMON OR DRILLED SHAFT, ROCK. THE COST OF ALL CONCRETE, REINFORCING STEEL, STEEL CASING, SPACERS, CSL ACCESS TUBES, DRILLING, LABOR AND ALL OTHER MISCELLANEOUS MATERIALS REQUIRED FOR PLACEMENT OF DRILLED SHAFTS SHALL BE INCIDENTAL TO THE UNIT PRICE BID FOR DRILLED SHAFTS (COMMON), AND DRILLED SHAFTS (ROCK).
- THE LENGTH REQUIRED FOR SPIRAL REINFORCEMENT IS THE DISTANCE FROM 3' ABOVE THE BOTTOM OF THE DRILLED SHAFT TO 3' BELOW THE TOP OF SHAFT. THE NUMBER OF TURNS IS THE LENGTH DIVIDED BY THE PITCH, PLUS THREE TURNS (TOTAL NUMBER OF CLOSED COILS) EXPRESSED TO THE NEAREST WHOLE NUMBER. ONE AND ONE-HALF CLOSED COILS SHALL BE PROVIDED AT THE ENDS OF EACH SPIRAL UNIT. FOUR CHANNEL, TEE OR ANGLE SPACERS, WITH AN APPROXIMATE WEIGHT OF 0.80 LBS PER FOOT OF SPACER SHALL BE PROVIDED FOR EACH SPIRAL UNIT. THEY SHALL BE EQUALLY SPACED AROUND THE PERIPHERY OF THE COIL. COST OF SPACERS IS INCIDENTAL TO THE COST OF DRILLED SHAFTS.
- SPLICES FOR SPIRALS WHERE DESIRED BY THE CONTRACTOR SHALL BE MADE WITH A MINIMUM OF ONE AND ONE-HALF TURNS OF SPIRAL. NO ADDITIONAL PAYMENT WILL BE MADE FOR THESE SPLICES, AND THE COST WILL BE CONSIDERED INCIDENTAL TO THE COST OF DEVELOPED-LENGTH OF SPIRAL SHOWN ON PLANS. SPIRAL REINFORCEMENT SHALL MEET THE REQUIREMENTS OF SUB-SECTION 811.02(C) OF THE SPECIFICATIONS.
- SPLICING OF LONGITUDINAL REINFORCEMENT: THE FIRST SPLICE FOR LONGITUDINAL REINFORCEMENT SHALL BE 40', MINIMUM, FROM THE TOP OF SHAFT. NO MORE THAN 50% OF THE LONGITUDINAL REINFORCEMENT SHALL BE SPLICED WITHIN ONE SPLICE LENGTH OF ANY LOCATION OR WITHIN 3 FEET OF THE SPLICE LOCATION IF MECHANICAL CONNECTORS ARE USED. MECHANICAL CONNECTORS SHALL DEVELOP A MINIMUM OF 125% OF THE YIELD STRENGTH OF THE LONGITUDINAL REINFORCEMENT. WHEN A DRILLED SHAFT IS LENGTHENED IN THE FIELD, 100% OF THE LONGITUDINAL REINFORCEMENT MAY BE SPLICED AT THE BOTTOM OF THE REINFORCEMENT CAGE.
- NONDESTRUCTIVE DRILLED SHAFT INTEGRITY TESTING SHALL BE PERFORMED ON EVERY FOURTH DRILLED SHAFT, 14 DRILLED SHAFTS OF THE 54 TOTAL DRILLED SHAFTS, USING THE CROSSHOLE SONIC LOGGING (CSL) METHOD. TESTING SHALL CONFORM TO THE 'SPECIAL NOTE FOR NONDESTRUCTIVE TESTING OF DRILLED SHAFTS'. THE BASIS FOR PAYMENT FOR DRILLED SHAFT TESTING SHALL BE AT THE UNIT PRICE BID FOR CSL TESTING. CSL ACCESS TUBES ARE INCIDENTAL TO THE COST OF DRILLED SHAFTS AND CSL TESTING MOBILIZATION IS INCIDENTAL TO THE COST OF CSL TESTING.
- THE PERMANENT STEEL CASINGS ARE SHOWN BEING KEYED INTO TOP OF ROCK. HOWEVER, IN NO CASE SHALL CASINGS EXTEND BELOW BASE OF WEATHERED ROCK SINCE A PORTION OF THE BEARING CAPACITY OF DRILLED SHAFTS IS BASED ON DEVELOPMENT OF SIDE FRICTION BETWEEN CONCRETE AND SOLID ROCK IN THE ROCK SOCKET.
- DUE TO THE POSSIBILITY OF ENCOUNTERING KARST FEATURES, ADDITIONAL EXPLORATION (INCLUDING ROCK SOUNDINGS AND ROCK CORINGS) SHALL BE REQUIRED DURING CONSTRUCTION AT EACH DRILLED SHAFT LOCATION PRIOR TO THE START OF DRILLED SHAFT CONSTRUCTION. THE ROCK CORING LENGTH IN THE ESTIMATE OF QUANTITIES IS BASED ON A PER SHAFT LENGTH OF THE ROCK SOCKET LENGTH PLUS FOUR TIMES THE ROCK SOCKET DIAMETER. CONTRARY TO THE 'SPECIAL NOTE FOR DRILLED SHAFTS', BORING LOGS AND FIELD NOTES FROM THE SUBSURFACE EXPLORATION SHALL BE FORWARDED TO THE ENGINEER AT LEAST 21 DAYS PRIOR TO COMMENCING DRILLED SHAFT CONSTRUCTION. THE ENGINEER WILL REVISE THE PLAN BOTTOM OF SHAFT ELEVATIONS WITHIN 14 DAYS. DURING CONSTRUCTION, THE ENGINEER MAY ADJUST THE BOTTOM OF SHAFT ELEVATION BASED ON RESULTS OF DRILLING THE ACTUAL ROCK SOCKET.
- THE CONTRACTOR SHALL DEMONSTRATE THE PROPOSED TECHNIQUE FOR CONSTRUCTING THE DRILLED SHAFTS BY CONSTRUCTING A TECHNIQUE SHAFT IN ACCORDANCE WITH THE 'SPECIAL NOTE FOR DRILLED SHAFTS'. THE TECHNIQUE SHAFT SHALL BE USED AS A PRODUCTION SHAFT. THE TECHNIQUE SHAFT SHALL BE CSL TESTED. THE PAYMENT FOR THE TECHNIQUE SHAFT WILL BE AT THE UNIT PRICE BID FOR THE PRODUCTION SHAFTS. IF THE TECHNIQUE SHAFT IS FOUND TO BE UNACCEPTABLE FOR USE IN THE COMPLETED STRUCTURE, IT SHALL BE REMOVED AND REPLACED IN THE SAME LOCATION AT NO ADDITIONAL EXPENSE TO THE DEPARTMENT. NO DRILLED SHAFT CONSTRUCTION SHALL BE ALLOWED UNTIL THE TECHNIQUE SHAFT IS COMPLETED, CSL TESTING IS COMPLETED AND THE TECHNIQUE SHAFT IS ACCEPTED BY THE ENGINEER.

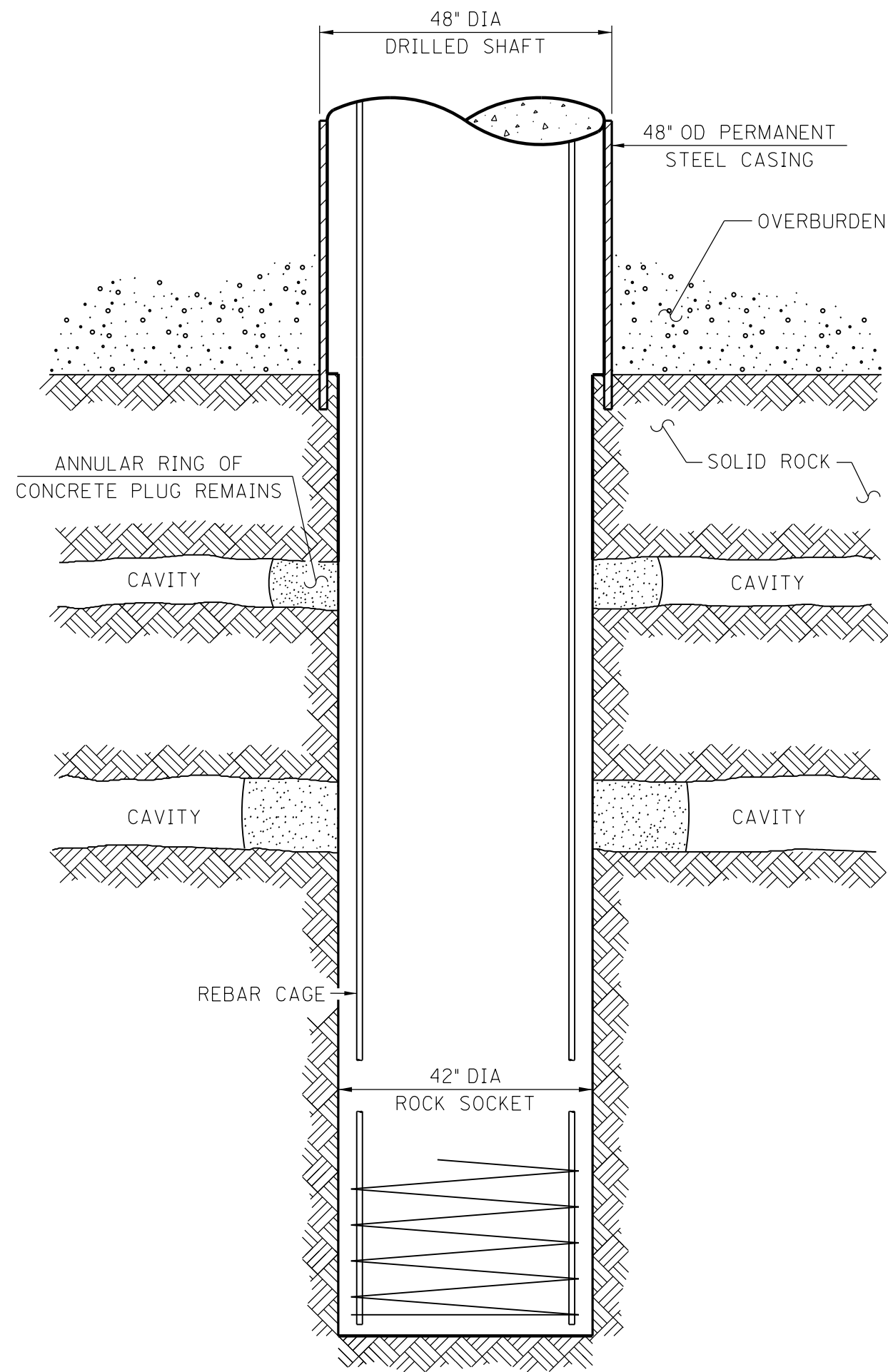

PROPOSED CAVITY REMEDIATION CONCRETE FILL METHOD

N. T. S.

- DRILL ROCK SOCKET TO BE BELOW LOWEST CAVITY.
- PLACE CLASS B CONCRETE IN SOCKET TO 12" ABOVE HIGHEST CAVITY, PLUGGING CAVITIES.
- ALLOW 2 DAY SET ON CONCRETE.
- RE-DRILL THROUGH CONCRETE, ADVANCE ROCK SOCKET TO BEARING ELEVATION IN PLANS OR AS DETERMINED BY THE ENGINEER BASED ON RESULTS OF PRE-INSTALLATION CORE HOLES.
- MONITOR SHAFT BOTTOM AFTER REMEDIATION UNTIL REBAR CAGE IS INSTALLED TO DETECT ANY SEDIMENT BUILD-UP IN BOTTOM OF SHAFT.

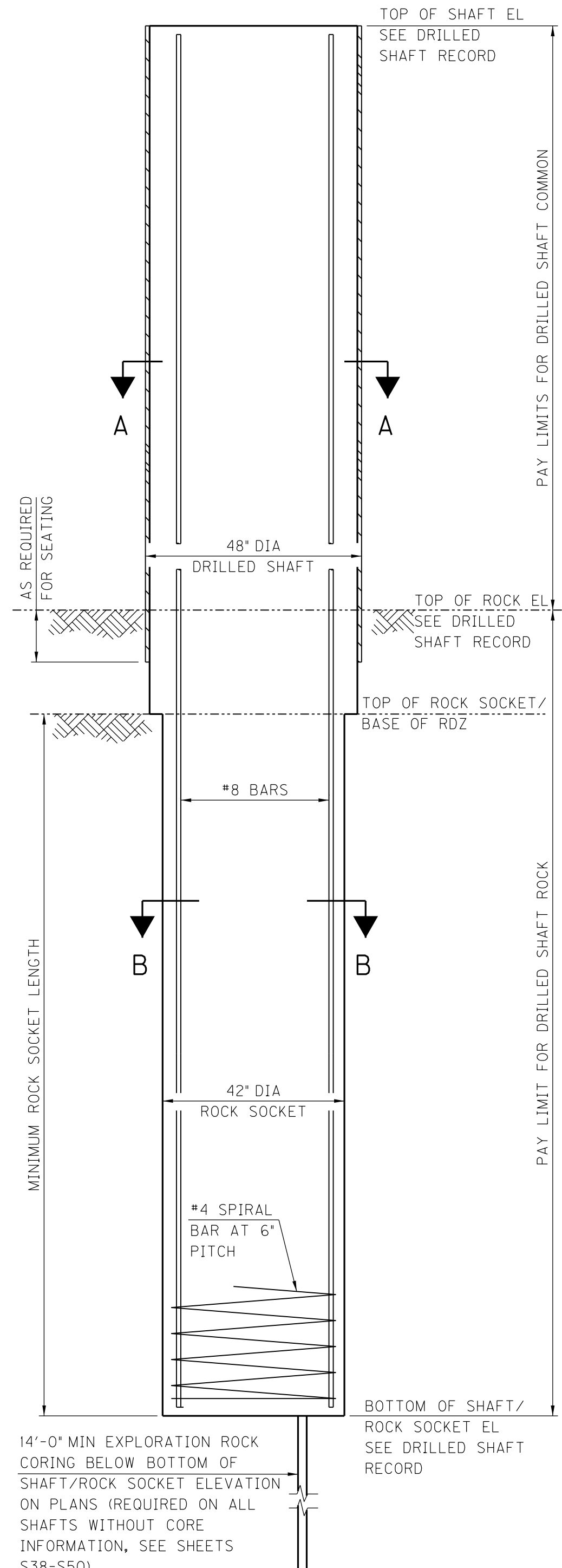

48" DIA DRILLED SHAFT REMEDIATION NOTES

- THE CONTRACTOR SHALL SUBMIT A DRILLED SHAFT CAVITY REMEDIATION PLAN FOR APPROVAL PRIOR TO BEGINNING DRILLED SHAFT CONSTRUCTION. IF THE CONTRACTOR DESIRES TO USE A DIFFERENT REMEDIATION TECHNIQUE THAN THE PROPOSED TECHNIQUE, DETAILS OF THE ALTERNATE CAVITY REMEDIATION METHOD MUST BE INCLUDED IN THE DRILLED SHAFT CAVITY REMEDIATION PLAN.
 - SMALLER CAVITIES MAY NOT REQUIRE REMEDIATION PRIOR TO REINFORCING CASE INSTALLATION. THE CAVITY REMEDIATION PLAN SHALL INCLUDE THOSE CAVITY LOCATIONS WHICH THE CONTRACTOR PROPOSES DO NOT REQUIRE REMEDIATION.
 - ALL COSTS ASSOCIATED WITH THE REMEDIATION OF CAVITIES SHALL BE INCLUDED IN THE DRILLED SHAFT 42" ROCK BID ITEM.
- THE COST OF ALL CONCRETE, DRILLING, LABOR AND ALL MISCELLANEOUS MATERIALS REQUIRED FOR CAVITY REMEDIATION SHALL BE INCLUDED IN THE BID ITEM FOR CONCRETE CLASS B.

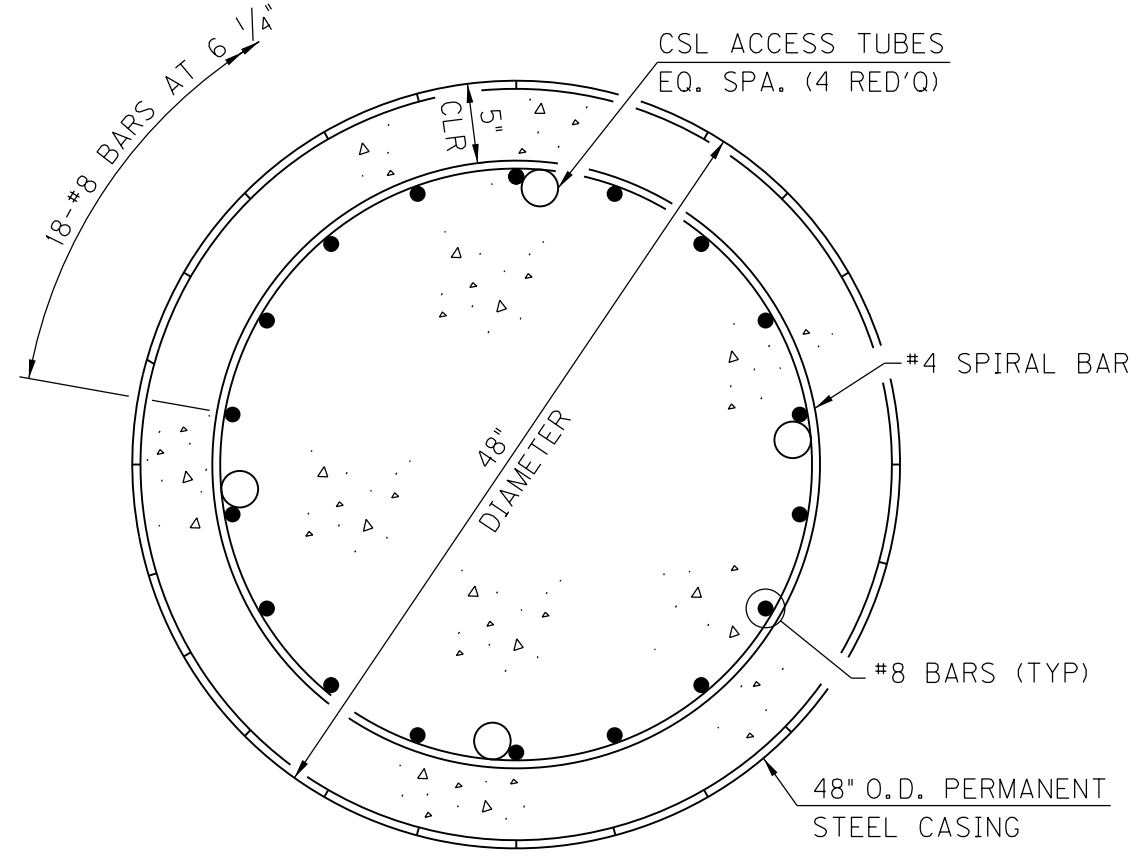

SECTION A-A (DRILLED SHAFT)

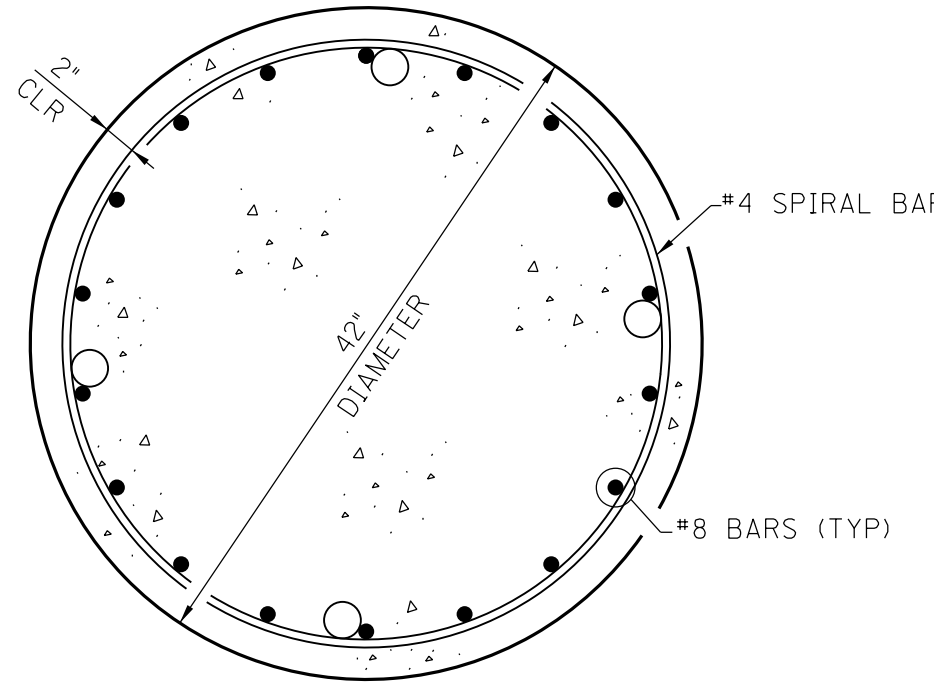

SECTION B-B (ROCK SOCKET)

DRILLED SHAFT RECORD

SHAFT NUMBER	AS SHOWN ON PLANS							AS CONSTRUCTED				
	DESIGN AXIAL LOAD (TONS)	DESIGN HORIZONTAL LOAD (KIPS)	TOP OF SHAFT ELEVATION	TOP OF ROCK ELEVATION	BOTTOM OF SHAFT/ROCK SOCKET ELEVATION	LENGTH OF DRILLED SHAFT, COMMON (FEET)	MINIMUM ROCK SOCKET LENGTH (FEET)	LENGTH OF DRILLED SHAFT, ROCK (FEET)	TOP OF ROCK SOCKET ELEVATION	BOTTOM OF SHAFT ELEVATION	LENGTH OF DRILLED SHAFT, ROCK (FEET)	LENGTH OF ROCK SOCKET (FEET)
1	44.5	22.8	959.38	954.70	945.50	4.68	8.0	9.20				
2			959.38	954.67	945.90	4.71	8.0	8.77				
3			959.38	954.63	944.20	4.75	10.0	10.43				
4			958.54	954.59	944.60	3.95	10.0	9.99				
5			958.54	953.83	943.80	4.71	10.0	10.03				
6			958.54	953.06	939.00	5.48	14.0	14.06				
7			958.54	952.31	938.30	6.23	14.0	14.01				
8			958.54	953.38	938.20	5.16	14.0	15.18				
9			958.54	954.44	942.00	4.10	10.0	12.44				
10			958.54	955.48	943.90	3.06	8.0	11.58				
11			958.54	953.55	943.00	4.99	8.0	10.55				
12			958.54	951.63	942.10	6.91	8.0	9.53				
13			958.54	949.70	941.30	8.84	8.0	8.40				
14			958.54	949.27	939.40	9.27	8.0	9.87				
15			958.54	948.83	937.50	9.71	8.0	11.33				
16			958.54	948.38	935.80	10.16	8.0	12.58				
17			957.71	946.14	933.90	11.57	8.0	12.24				
18			957.71	943.91	932.00	13.80	8.0	11.91				
19			957.71	941.66	930.30	16.05	8.0	11.36				
20			957.71	938.60	927.20	19.11	8.0	11.40				
21			957.71	935.53	924.30	22.18	8.0	11.23				
22			957.71	932.51	921.60	25.20	8.0	10.91				
23			956.88	933.75	922.50	23.13	8.0	11.25				
24			956.88	934.98	923.40	21.90	8.0	11.58				
25			956.88	936.21	924.30	20.67	8.0	11.91				
26			956.88	937.11	925.10	19.77	8.0	12.01				
27			956.88	938.01	926.00	18.87	8.0	12.01				
28			956.88	938.90	926.90	17.98	8.0	12.00				
29			956.04	939.17	927.30	16.87	8.0	11.87				
30			956.04	939.44	927.70	16.60	8.0	11.74				
31			956.04	939.70	928.10	16.34	8.0	11.60				
32			956.04	939.57	927.80	16.47	8.0	11.77				
33			956.04	939.43	927.50	16.61	8.0	11.93				
34			956.04	939.29	927.20	16.75	8.0	12.09				
35			955.21	938.50	927.50	16.71	8.0	11.00				
36			955.21	937.71	927.90	17.50	8.0	9.81				
37			955.21	936.93	928.20	18.28	8.0	8.73				
38			955.21	937.54	928.80	17.67	8.0	8.74				
39			955.21	938.15	929.50	17.06	8.0	8.65				
40			955.21	938.78	930.20	16.43	8.0	8.58				
41			954.38	939.49	931.10	14.89	8.0	8.39				
42			954.38	940.20	932.00	14.18	8.0	9.20				
43			954.38	940.91	932.90	13.47	8.0	8.01				
44			954.38	941.67	933.00	12.71	8.0	8.67				
45			954.38	942.44	933.00	11.94	8.0	9.44				
46			954.38	943.21	933.10	11.17	8.0	10.11				
47			953.54	944.04	933.10	9.50	8.0	10.94				
48			953.54	944.88	933.10	8.66	8.0	11.78				
49			953.54	945.69	933.10	7.85	8.0	12.59				
50			953.54	944.52	932.50	9.02	8.0	12.02				
51			953.54	943.35	931.90	10.19	8.0	11.45				
52			953.54	942.20	931.30	11.34	8.0	10.90				
53			952.71	941.76	930.80	10.95	8.0	10.96				
54	44.5	22.8	952.71	941.32	930.40	11.39	8.0	10.92				

DRILLED SHAFT RECORD NOTES

- DESIGN LOADS SHOWN ARE BASED ON UNFACTORED (SERVICE LOAD) GROUP LOADINGS.
- THE DESIGNER SHALL DETERMINE THE BOTTOM OF SHAFT ELEVATIONS. ELEVATIONS FOR TOP OF ROCK AND TOP OF ROCK SOCKET SHALL BE DETERMINED IN THE FIELD BY THE ENGINEER TO DETERMINE PAY LENGTHS.
- 'TOP OF ROCK' AND 'BOTTOM OF SHAFT' PLAN ELEVATIONS ARE BASED ON BORINGS, AND ARE USED FOR PLAN QUANTITIES ONLY. FIELD ELEVATIONS AND PAY QUANTITIES MAY VARY FROM THESE PLAN VALUES.
- AS-CONSTRUCTED BOTTOM OF SHAFT ELEVATION SHALL BE AT OR BELOW BOTTOM OF SHAFT ELEVATION AS SHOWN ON PLANS.
- AFTER COMPLETING THE DRILLING OPERATIONS, THE RESIDENT ENGINEER SHALL COMPLETE THE DRILLED SHAFT RECORD. ONE COPY OF THE COMPLETED RECORD SHALL BE FORWARDED TO THE DIRECTOR, DIVISION OF STRUCTURAL DESIGN. THIS DRILLED SHAFT RECORD DOES NOT REPLACE OTHER RECORDS AND DOCUMENTATION REQUIRED. SEE THE SPECIAL NOTE FOR DRILLED SHAFTS FOR ADDITIONAL REQUIRED DRILLED SHAFT RECORDS.
- SHAFT SIZES AND DEPTHS HAVE BEEN SELECTED ON THE BASIS OF DESIGN AXIAL LOADS, AS SHOWN IN THE TABLE. THE ALLOWABLE END BEARING CAPACITY IN THE ROCK SOCKET IS 30 KSF. ADJUSTMENTS IN BOTTOM OF SHAFT ELEVATIONS SHALL BE MADE AS REQUIRED, BASED ON FIELD CONDITIONS. IN NO EVENT, HOWEVER, SHALL THE ROCK SOCKET LENGTH BE REDUCED FROM THE MINIMUM DIMENSION SPECIFIED IN THE TABLES BECAUSE LATERAL LOAD STRENGTH IS DEPENDENT UPON THE SPECIFIED MINIMUM SOCKET LENGTHS.

ITEM NUMBER
7-593.11

REVISION	DATE
Δ REVISED NOTES	10/13/11
DATE: 09/2011	CHECKED BY: M. LAWLER
DESIGNED BY: D. KAISER	DETAILED BY: R. YOUNG
A. SIEGERT	

Commonwealth of Kentucky
DEPARTMENT OF HIGHWAYS
 COUNTY
FAYETTE
NOISE BARRIER WALL AT NORFOLK SOUTHERN RR YARD
DRILLED SHAFTS
 PREPARED BY

SHEET NO. S16
DRAWING NO. 26505

DRILLED SHAFT GENERAL NOTES

- 1. DRILLED SHAFTS FOR THE NOISE WALLS SHALL BE CONSTRUCTED IN ACCORDANCE WITH THE 'SPECIAL NOTES FOR DRILLED SHAFTS', CURRENT EDITION, THE USE OF SUPERPLASTICIZERS IN THE CLASS 'A MODIFIED' CONCRETE IS NOT RECOMMENDED.
2. CONCRETE FOR DRILLED SHAFTS SHALL BE CLASS 'A MODIFIED', WITH A 28 DAY STRENGTH OF 4000 PSI.
3. PAYMENT FOR DRILLED SHAFTS SHALL BE EITHER DRILLED SHAFT, COMMON OR DRILLED SHAFT, ROCK. THE COST OF ALL CONCRETE, REINFORCING STEEL, STEEL CASING, SPACERS, CSL ACCESS TUBES, DRILLING, LABOR AND ALL OTHER MISCELLANEOUS MATERIALS REQUIRED FOR PLACEMENT OF DRILLED SHAFTS SHALL BE INCIDENTAL TO THE UNIT PRICE BID FOR DRILLED SHAFTS (COMMON), AND DRILLED SHAFTS (ROCK).
4. THE LENGTH REQUIRED FOR SPIRAL REINFORCEMENT IS THE DISTANCE FROM 3' ABOVE THE BOTTOM OF THE DRILLED SHAFT TO 3' BELOW THE TOP OF SHAFT. THE NUMBER OF TURNS IS THE LENGTH DIVIDED BY THE PITCH, PLUS THREE TURNS (TOTAL NUMBER OF CLOSED COILS) EXPRESSED TO THE NEAREST WHOLE NUMBER, ONE AND ONE-HALF CLOSED COILS SHALL BE PROVIDED AT THE ENDS OF EACH SPIRAL UNIT. FOUR CHANNEL, TEE OR ANGLE SPACERS, WITH AN APPROXIMATE WEIGHT OF 0.80 LBS PER FOOT OF SPACER SHALL BE PROVIDED FOR EACH SPIRAL UNIT. THEY SHALL BE EQUALLY SPACED AROUND THE PERIPHERY OF THE COIL. COST OF SPACERS IS INCIDENTAL TO THE COST OF DRILLED SHAFTS.
5. SPLICES FOR SPIRALS WHERE DESIRED BY THE CONTRACTOR SHALL BE MADE WITH A MINIMUM OF ONE AND ONE-HALF TURNS OF SPIRAL. NO ADDITIONAL PAYMENT WILL BE MADE FOR THESE SPLICES, AND THE COST WILL BE CONSIDERED INCIDENTAL TO THE COST OF DEVELOPED-LENGTH OF SPIRAL SHOWN ON PLANS. SPIRAL REINFORCEMENT SHALL MEET THE REQUIREMENTS OF SUB-SECTION 811.02(C) OF THE SPECIFICATIONS.
6. SPLICING OF LONGITUDINAL REINFORCEMENT: THE FIRST SPLICE FOR LONGITUDINAL REINFORCEMENT SHALL BE 40', MINIMUM, FROM THE TOP OF SHAFT. NO MORE THAN 50% OF THE LONGITUDINAL REINFORCEMENT SHALL BE SPLICED WITHIN ONE SPLICE LENGTH OF ANY LOCATION OR WITHIN 3 FEET OF THE SPLICE LOCATION IF MECHANICAL CONNECTORS ARE USED. MECHANICAL CONNECTORS SHALL DEVELOP A MINIMUM OF 125% OF THE YIELD STRENGTH OF THE LONGITUDINAL REINFORCEMENT. WHEN A DRILLED SHAFT IS LENGTHENED IN THE FIELD, 100% OF THE LONGITUDINAL REINFORCEMENT MAY BE SPLICED AT THE BOTTOM OF THE REINFORCEMENT CAGE.
7. NONDESTRUCTIVE DRILLED SHAFT INTEGRITY TESTING SHALL BE PERFORMED ON EVERY FOURTH DRILLED SHAFT, 14 DRILLED SHAFTS OF THE 54 TOTAL DRILLED SHAFTS, USING THE CROSSHOLE SONIC LOGGING (CSL) METHOD. TESTING SHALL CONFORM TO THE 'SPECIAL NOTE FOR NONDESTRUCTIVE TESTING OF DRILLED SHAFTS'. THE BASIS FOR PAYMENT FOR DRILLED SHAFT TESTING SHALL BE AT THE UNIT PRICE BID FOR CSL TESTING. CSL ACCESS TUBES ARE INCIDENTAL TO THE COST OF DRILLED SHAFTS AND CSL TESTING MOBILIZATION IS INCIDENTAL TO THE COST OF CSL TESTING.
8. THE PERMANENT STEEL CASINGS ARE SHOWN BEING KEYED INTO TOP OF ROCK. HOWEVER, IN NO CASE SHALL CASINGS EXTEND BELOW BASE OF WEATHERED ROCK SINCE A PORTION OF THE BEARING CAPACITY OF DRILLED SHAFTS IS BASED ON DEVELOPMENT OF SIDE FRICTION BETWEEN CONCRETE AND SOLID ROCK IN THE ROCK SOCKET.
9. DUE TO THE POSSIBILITY OF ENCOUNTERING KARST FEATURES, ADDITIONAL EXPLORATION (INCLUDING ROCK SOUNDINGS AND ROCK CORINGS) SHALL BE REQUIRED DURING CONSTRUCTION AT EACH DRILLED SHAFT LOCATION PRIOR TO THE START OF DRILLED SHAFT CONSTRUCTION. THE ROCK CORING LENGTH IN THE ESTIMATE OF QUANTITIES IS BASED ON A PER SHAFT LENGTH OF THE ROCK SOCKET LENGTH PLUS FOUR TIMES THE ROCK SOCKET DIAMETER. CONTRARY TO THE 'SPECIAL NOTE FOR DRILLED SHAFTS', BORING LOGS AND FIELD NOTES FROM THE SUBSURFACE EXPLORATION SHALL BE FORWARDED TO THE ENGINEER AT LEAST 21 DAYS PRIOR TO COMMENCING DRILLED SHAFT CONSTRUCTION. THE ENGINEER WILL REVISE THE PLAN BOTTOM OF SHAFT ELEVATIONS WITHIN 14 DAYS. DURING CONSTRUCTION, THE ENGINEER MAY ADJUST THE BOTTOM OF SHAFT ELEVATION BASED ON RESULTS OF DRILLING THE ACTUAL ROCK SOCKET.
10. THE CONTRACTOR SHALL DEMONSTRATE THE PROPOSED TECHNIQUE FOR CONSTRUCTING THE DRILLED SHAFTS BY CONSTRUCTING A TECHNIQUE SHAFT IN ACCORDANCE WITH THE 'SPECIAL NOTE FOR DRILLED SHAFTS'. THE TECHNIQUE SHAFT SHALL BE USED AS A PRODUCTION SHAFT. THE TECHNIQUE SHAFT SHALL BE CSL TESTED. THE PAYMENT FOR THE TECHNIQUE SHAFT WILL BE AT THE UNIT PRICE BID FOR THE PRODUCTION SHAFTS. IF THE TECHNIQUE SHAFT IS FOUND TO BE UNACCEPTABLE FOR USE IN THE COMPLETED STRUCTURE, IT SHALL BE REMOVED AND REPLACED IN THE SAME LOCATION AT NO ADDITIONAL EXPENSE TO THE DEPARTMENT. NO DRILLED SHAFT CONSTRUCTION SHALL BE ALLOWED UNTIL THE TECHNIQUE SHAFT IS COMPLETED, CSL TESTING IS COMPLETED AND THE TECHNIQUE SHAFT IS ACCEPTED BY THE ENGINEER.

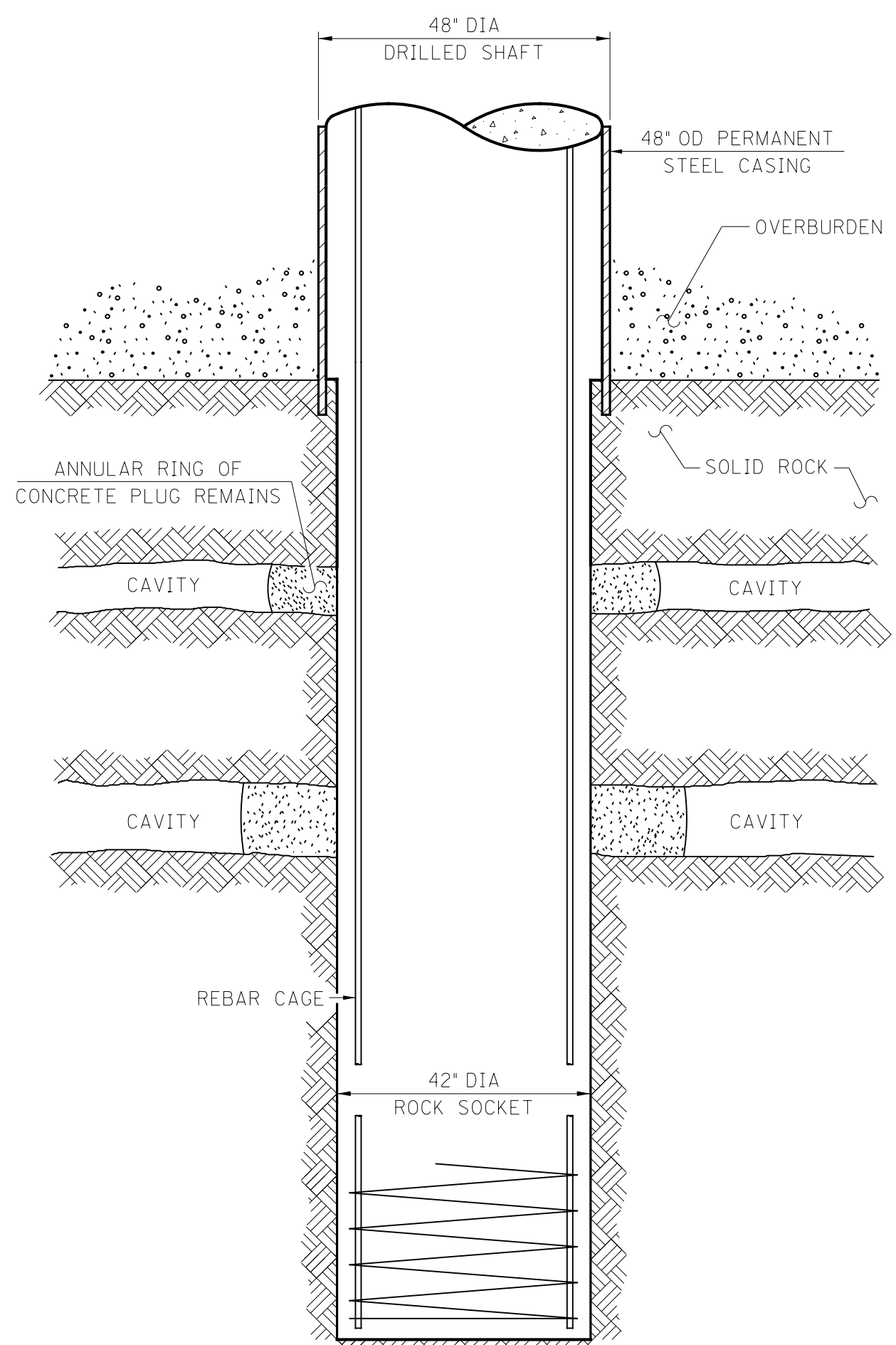

PROPOSED CAVITY REMEDIATION CONCRETE FILL METHOD

N. T. S.

- 1. DRILL ROCK SOCKET TO BE BELOW LOWEST CAVITY.
2. PLACE CLASS B CONCRETE IN SOCKET TO 12" ABOVE HIGHEST CAVITY, PLUGGING CAVITIES.
3. ALLOW 2 DAY SET ON CONCRETE.
4. RE-DRILL THROUGH CONCRETE, ADVANCE ROCK SOCKET TO BEARING ELEVATION IN PLANS OR AS DETERMINED BY THE ENGINEER BASED ON RESULTS OF PRE-INSTALLATION CORE HOLES.
5. MONITOR SHAFT BOTTOM AFTER REMEDIATION UNTIL REBAR CAGE IS INSTALLED TO DETECT ANY SEDIMENT BUILD-UP IN BOTTOM OF SHAFT.

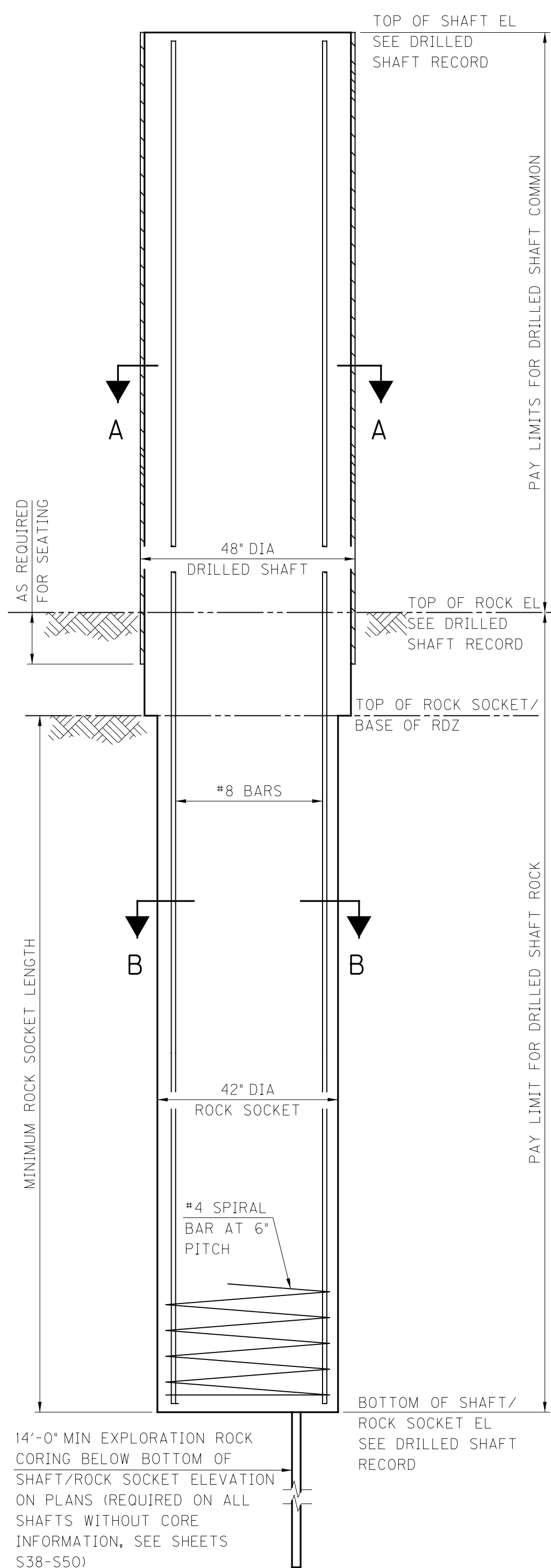

48" DIA DRILLED SHAFT REMEDIATION NOTES

- 1. THE CONTRACTOR SHALL SUBMIT A DRILLED SHAFT CAVITY REMEDIATION PLAN FOR APPROVAL PRIOR TO BEGINNING DRILLED SHAFT CONSTRUCTION. IF THE CONTRACTOR DESIRES TO USE A DIFFERENT REMEDIATION TECHNIQUE THAN THE PROPOSED TECHNIQUE, DETAILS OF THE ALTERNATE CAVITY REMEDIATION METHOD MUST BE INCLUDED IN THE DRILLED SHAFT CAVITY REMEDIATION PLAN.
2. SMALLER CAVITIES MAY NOT REQUIRE REMEDIATION PRIOR TO REINFORCING CASE INSTALLATION. THE CAVITY REMEDIATION PLAN SHALL INCLUDE THOSE CAVITY LOCATIONS WHICH THE CONTRACTOR PROPOSES DO NOT REQUIRE REMEDIATION.
3. ALL COSTS ASSOCIATED WITH THE REMEDIATION OF CAVITIES SHALL BE INCLUDED IN THE DRILLED SHAFT 42" ROCK BID ITEM.
THE COST OF ALL CONCRETE, DRILLING, LABOR AND ALL MISCELLANEOUS MATERIALS REQUIRED FOR CAVITY REMEDIATION SHALL BE INCLUDED IN THE BID ITEM FOR CONCRETE CLASS B.

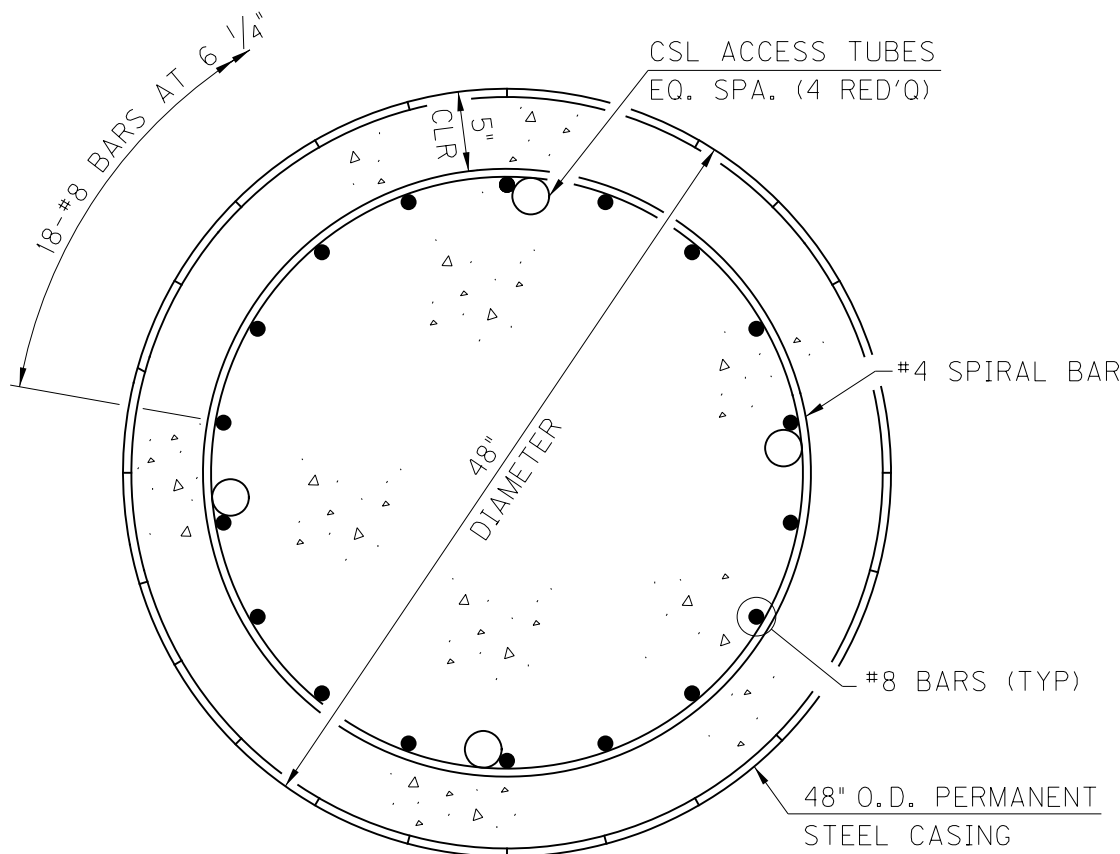

SECTION A-A (DRILLED SHAFT)

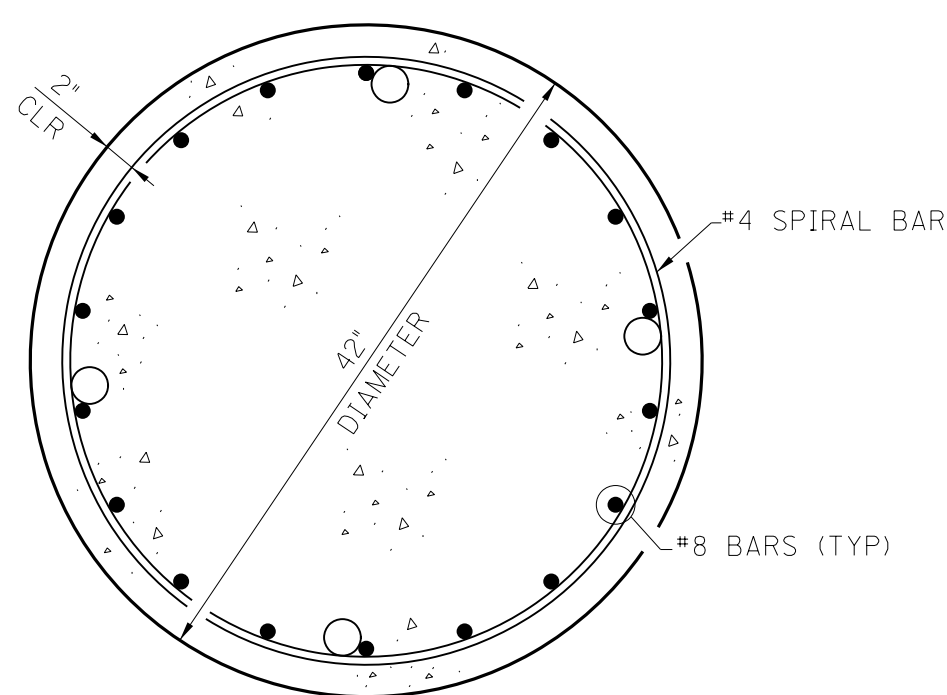

SECTION B-B (ROCK SOCKET)

DRILLED SHAFT RECORD

Table with columns: SHAFT NUMBER, DESIGN AXIAL LOAD (TONS), DESIGN HORIZONTAL LOAD (KIPS), TOP OF SHAFT ELEVATION, TOP OF ROCK ELEVATION, BOTTOM OF SHAFT / ROCK SOCKET ELEVATION, LENGTH OF DRILLED SHAFT, COMMON (FEET), MINIMUM ROCK SOCKET LENGTH (FEET), LENGTH OF DRILLED SHAFT, ROCK (FEET), TOP OF ROCK SOCKET ELEVATION, BOTTOM OF SHAFT ELEVATION, LENGTH OF DRILLED SHAFT, ROCK (FEET), LENGTH OF ROCK SOCKET (FEET). Rows 1-54.

DRILLED SHAFT RECORD NOTES

- 1. DESIGN LOADS SHOWN ARE BASED ON UNFACTORED (SERVICE LOAD) GROUP LOADINGS.
2. THE DESIGNER SHALL DETERMINE THE BOTTOM OF SHAFT ELEVATIONS. ELEVATIONS FOR TOP OF ROCK AND TOP OF ROCK SOCKET SHALL BE DETERMINED IN THE FIELD BY THE ENGINEER TO DETERMINE PAY LENGTHS.
'TOP OF ROCK' AND 'BOTTOM OF SHAFT' PLAN ELEVATIONS ARE BASED ON BORINGS, AND ARE USED FOR PLAN QUANTITIES ONLY. FIELD ELEVATIONS AND PAY QUANTITIES MAY VARY FROM THESE PLAN VALUES.
3. AS-CONSTRUCTED BOTTOM OF SHAFT ELEVATION SHALL BE AT OR BELOW BOTTOM OF SHAFT ELEVATION AS SHOWN ON PLANS.
4. AFTER COMPLETING THE DRILLING OPERATIONS, THE RESIDENT ENGINEER SHALL COMPLETE THE DRILLED SHAFT RECORD. ONE COPY OF THE COMPLETED RECORD SHALL BE FORWARDED TO THE DIRECTOR, DIVISION OF STRUCTURAL DESIGN. THIS DRILLED SHAFT RECORD DOES NOT REPLACE OTHER RECORDS AND DOCUMENTATION REQUIRED. SEE THE SPECIAL NOTE FOR DRILLED SHAFTS FOR ADDITIONAL REQUIRED DRILLED SHAFT RECORDS.
5. SHAFT SIZES AND DEPTHS HAVE BEEN SELECTED ON THE BASIS OF DESIGN AXIAL LOADS, AS SHOWN IN THE TABLE. THE ALLOWABLE END BEARING CAPACITY IN THE ROCK SOCKET IS 30 KSF. ADJUSTMENTS IN BOTTOM OF SHAFT ELEVATIONS SHALL BE MADE AS REQUIRED, BASED ON FIELD CONDITIONS. IN NO EVENT, HOWEVER, SHALL THE ROCK SOCKET LENGTH BE REDUCED FROM THE MINIMUM DIMENSION SPECIFIED IN THE TABLES BECAUSE LATERAL LOAD STRENGTH IS DEPENDENT UPON THE SPECIFIED MINIMUM SOCKET LENGTHS.

Table with columns: ITEM NUMBER, 7-593.11

Commonwealth of Kentucky DEPARTMENT OF HIGHWAYS COUNTY FAYETTE NOISE BARRIER WALL AT NORFOLK SOUTHERN RR YARD DRILLED SHAFTS PREPARED BY ENTRAN SHEET NO. S16 DRAWING NO. 26505

CONTRACT ID: 111048
COUNTY: FAYETTE
PROPOSAL: STPM 3003(250)

PAGE: 1
LETTING: 10/21/11
CALL NO: 106

LINE NO	ITEM	DESCRIPTION	APPROXIMATE QUANTITY	UNIT	UNIT PRICE	AMOUNT
SECTION 0001 NOISE BARRIER WALL						
0010	00461	CULVERT PIPE-15 IN	112.000	LF		
0020	02230	EMBANKMENT IN PLACE	15,735.000	CUYD		
0030	02483	CHANNEL LINING CLASS II	10.500	TON		
0040	02545	CLEARING AND GRUBBING 2.6 ACRES	(1.00)	LS		
0041	02555	CONCRETE-CLASS B (ADDED: 10-17-11)	25.000	CUYD		
0050	02726	STAKING	(1.00)	LS		
0060	02998	MASONRY COATING	5,720.000	SQYD		
0070	05950	EROSION CONTROL BLANKET	12,832.000	SQYD		
0080	08100	CONCRETE-CLASS A	4.500	CUYD		
0090	08150	STEEL REINFORCEMENT	42.000	LB		
0100	20745ED	ROCK SOUNDINGS	346.000	LF		
0110	20746ED	ROCK CORINGS	899.000	LF		
0120	21321NC	CSL TESTING (4 TUBES)	14.000	EACH		
0130	21590EN	SOUND BARRIER WALL	51,484.000	SQFT		
0140	23143ED	KPDES PERMIT AND TEMP EROSION CONTROL	(1.00)	LS		
0150	23583EC	DRILLED SHAFT-48 IN-COMMON	688.000	LF		
0160	23584EC	DRILLED SHAFT-42 IN-ROCK	589.000	LF		
SECTION 0002 MOB AND DEMOB						
0170	02568	MOBILIZATION (NO MORE THAN 5%)		LUMP		
0180	02569	DEMOBILIZATION (AT LEAST 1.5%)		LUMP		
		TOTAL BID				